

## Monday

This week for our English learning, we are going to be reading an extract from the story 'Norman the Norman from Normandy' by Philip Ardagh and completing some tasks. For today's task, read through the extract saved under the [Year 2 English](#) tab titled **Norman the Norman from Normandy**.

## Tuesday

Read the text again, this time looking out for words that you don't understand. Once you have found some words, write them into your book and use an online dictionary to find out what the words mean. If you understand all of the words, select a word that you might not usually use in your writing to improve your vocabulary. To help you remember the words in the future, create a Freyer Word card (see examples below). You can draw pictures to remind you what the word means and create examples and non-examples of what the word doesn't mean.

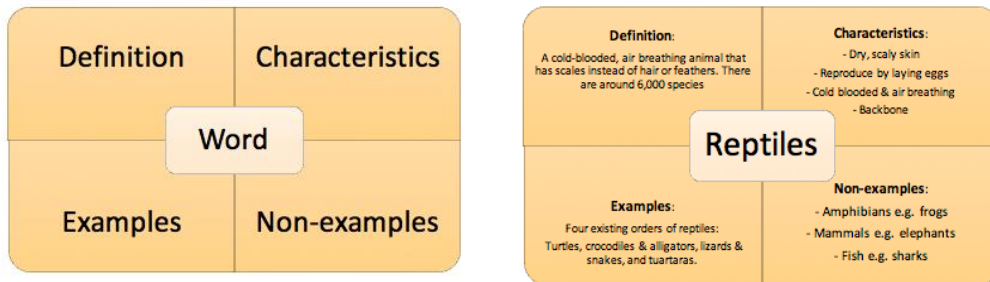

## Wednesday

Today we would like you to write a character description about Norman the Norman from Normandy. In the extract there is some description about what he is wearing and there is a picture to support your thinking. When you are writing your description, think about what Norman is like as a person. Do you think he is nice? Is he brave? In your books, write a description of at least 5 sentences. Make sure you use all of your Go Greens in your sentences!

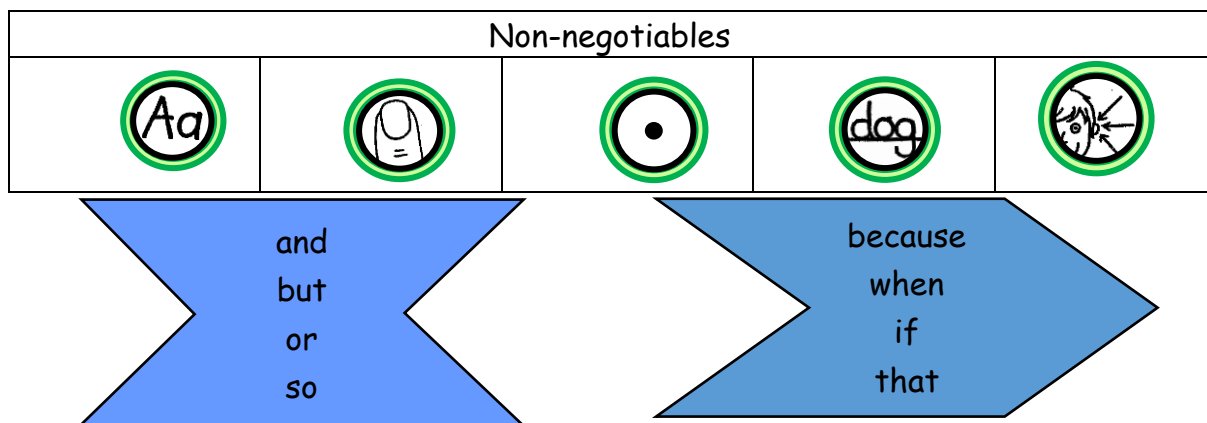

## Thursday

Today we would like you to create a story board for the first section of the story. Use the first 3 boxes for the current part of the story and use the next 3 boxes to create what you think will happen next. You will create a story board to help you write the next section of the story in tomorrow's learning. A template can be found on the next page.

The last line of the story says, '**Then the Bretons made the mistake of TELLING him- not asking him- to apologise.'**

Think about these questions when creating your story board:

1. What is going to happen next?
2. How will Great Big Norman react when he is told what to do?
3. What do you think the Bretons will do?

The storyboard template consists of two rows of three rectangular boxes each. Each box has a small circle in the top-left corner. Below each box are three horizontal lines for writing.

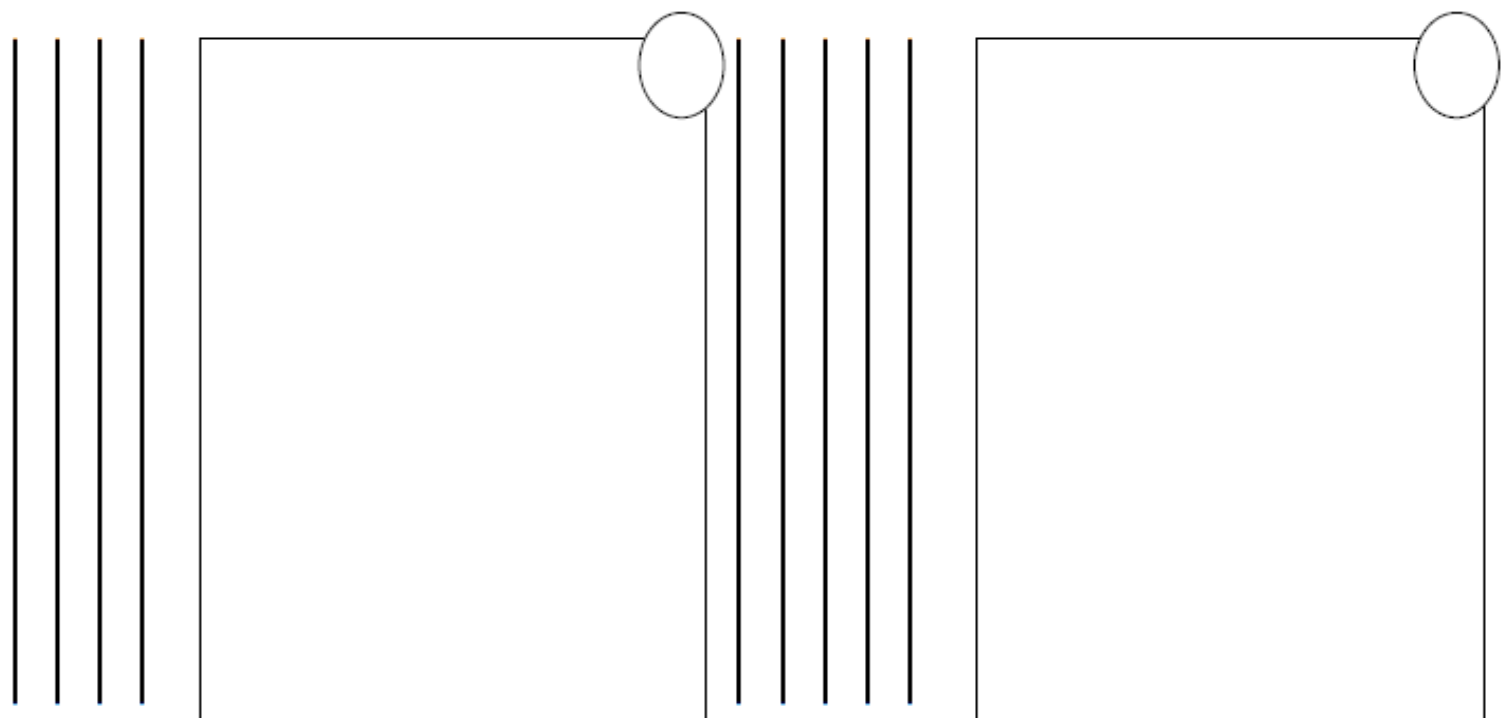
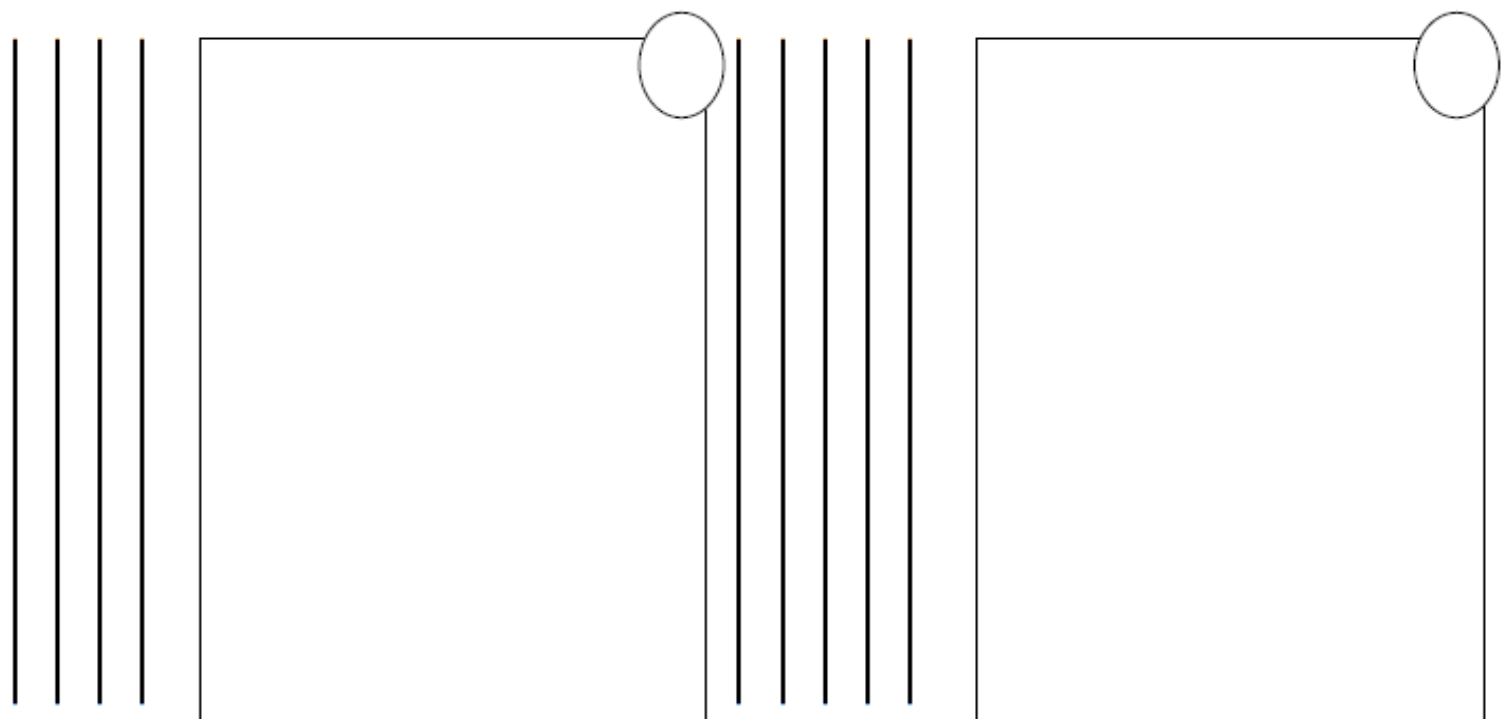
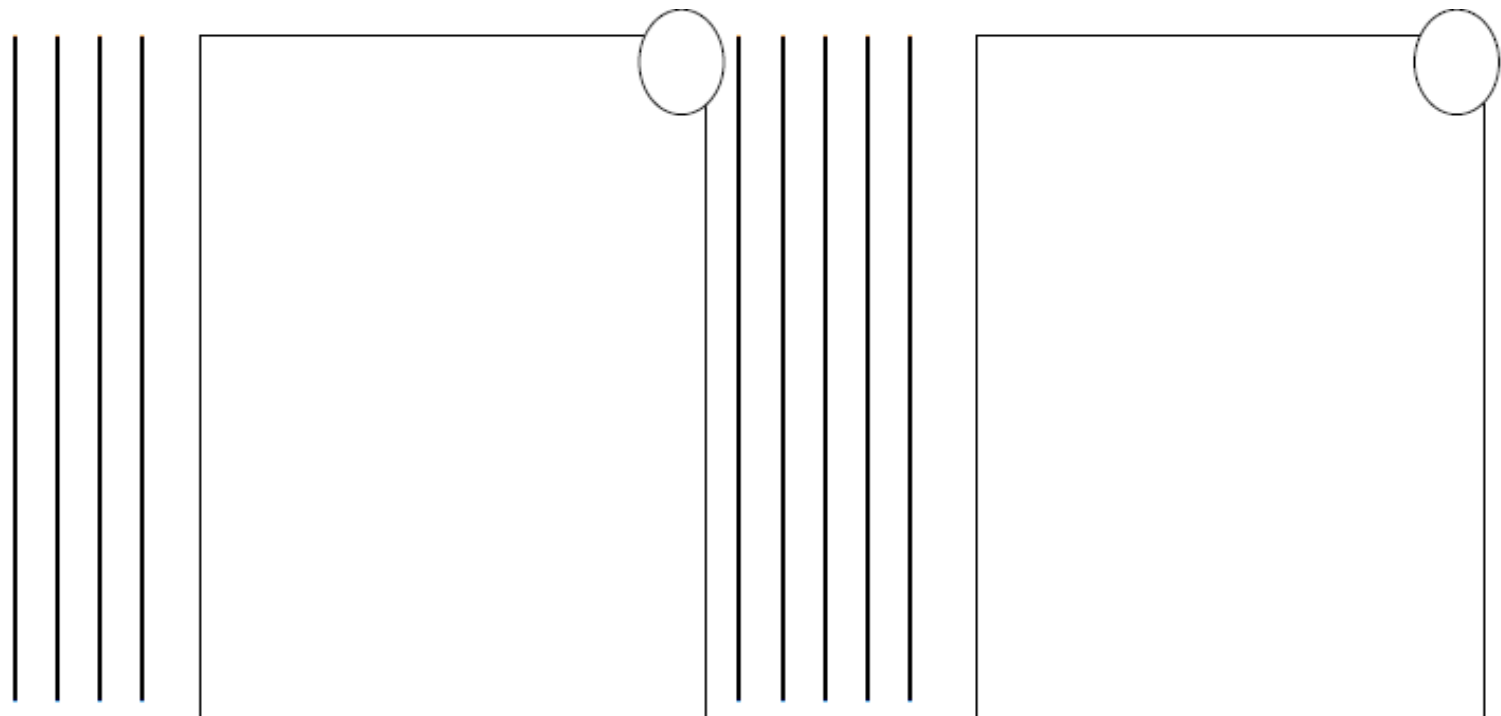

## Friday

For today's lesson, you will need to use your completed story board to create the next bit of the story. Think about your sentences and what key things you will need to include in your sentences to make them more interesting. Make sure you use your *Go Greens* (can be found on page 1), subordinating/ coordinating conjunctions, adjectives and make maybe even some commas in a list.

Write your story straight into your books or you could type your story in a Word document. Add pictures to add colour and detail to your stories.

We can't wait to see your outcomes!